

Naive beamforming for multi-element antenna GNSS receiver

I. V. Korogodin

National Research University Moscow Power Engineering Institute, Russia

Abstract— Antenna array beamforming is a useful technique for GNSS receivers for signal-to-noise improvement and multipath and interference mitigation. Any conventional beamforming algorithm implementation is complicated. The algorithm adds together different antenna signals with expected weights. To calculate the weights, it requires antenna elements' RP calibrations, receiver attitude determination and wide data channels between the CRPA and the receiver. A naive beamforming approach is described in this paper. It doesn't calculate expected weights for the desired beamforming direction. The algorithm directly estimates phase differences of the signals and use the estimations to focus them. As result, the proposed algorithm doesn't have the described disadvantages of the regular beamforming. Experimental results are presented. The used mock-up is based on a seven-element L1-band convex antenna array and a Xilinx Zynq-based navigation receiver. It is shown by the experiments, that beamforming allows to increase channel SNR about 7-8 dB. As result, root-mean-square pseudorange errors decrease 2-2.5 times.

1. INTRODUCTION

Global satellite navigation system (GNSS) receivers process several signals simultaneously. The signals are radiated by space vehicles (SV) moving on non-geostationary orbits. As result, non-directional antennas are used by the regular receivers.

On the other hand, directional properties would be useful: for signal-to-noise ratio (SNR) improvement, and multipath and interference mitigation [1], [2].

The properties can be obtained by means of controlled reception pattern antennas (CRPA). The antenna arrays allow forming virtual radiation patterns (RP) for each SV. The technique is known as beamforming.

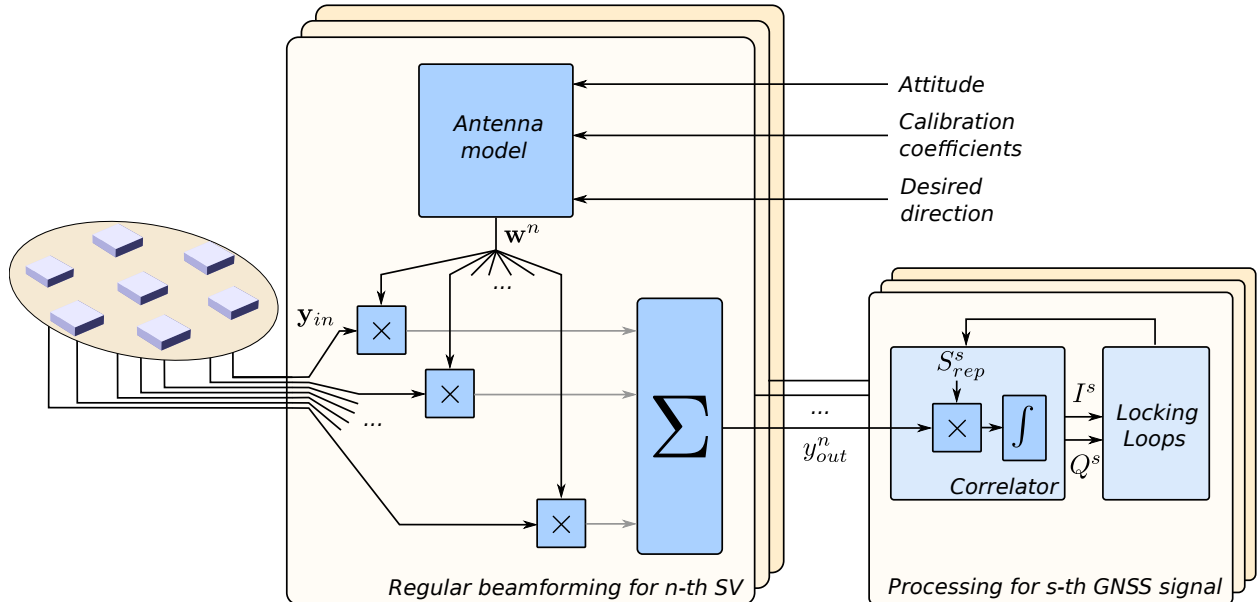

Figure 1: Conventional beamforming for GNSS receiver

Narrowband beamformers add together antenna elements signals with complex weights for focusing the θ direction [3], [4]:

$$y_{out} = \mathbf{w}(\theta)^T \mathbf{y}_{in}, \quad (1)$$

where $\mathbf{w}(\theta)$ is $M \times 1$ vector of the weights, \mathbf{y}_{in} is $M \times 1$ vector of the antenna element signals, and M is a number of antenna elements.

Complex weights shift signal phases. Conventional weights are calculated for the certain SV elevation/azimuth with consideration of the antenna attitude and antenna element RPs.

The first issue of the regular beamforming is to define the antenna array elements RPs. The properties of antenna elements vary between instances. Furthermore, the elements are mutually coupled in any antenna array. Even a backplane and surrounding items influence RP of each antenna element. The more the number of the elements, the more complex and laborious it is to calibrate the antenna.

The second beamforming issue is to determine the antenna attitude. The attitude, the beam direction, and elements RPs are used to form steering vector $\mathbf{w}(\theta)^\top$.

The third issue is to realize an interface between the CRPA and the receiver. Modern receivers are multi-system ones. CRPA should create beams to 30-40 satellites simultaneously. As result, there is a plenty of output signals corresponding to different virtual RPs.

2. NAIVE BEAMFORMING APPROACH

The conventional beamformers use a mathematical model of the antenna to calculate the weights. Received signals are not used in the calculation process. The model predicts signal phase differences for the desired angle-of-arrival. The differences are used to shift signal phases and to add together signals of the direction coherently (see Fig. 2).

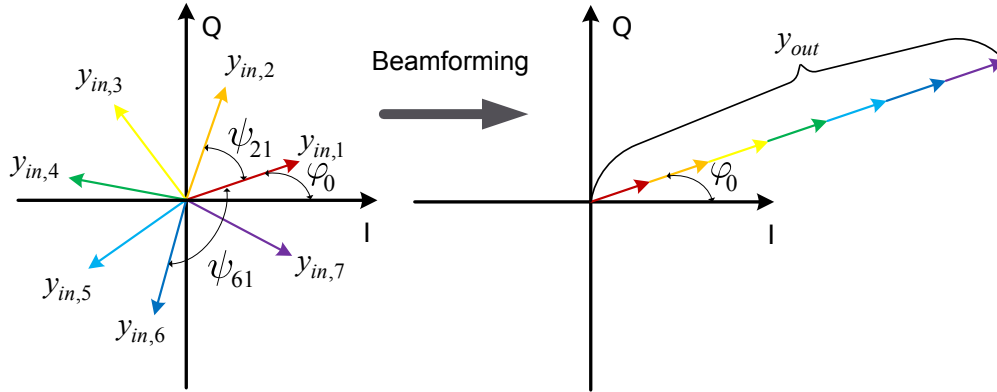

Figure 2: Beamforming like coherent accumulation

We need a complex enough antenna model for the signal phase differences prediction. The main idea of the proposed naive beamforming approach: **don't use the antenna model, but just estimate the phase differences directly!**

If a phase difference estimation algorithm works well enough, it produces weights which are very close to the conventional beamformer weights. In this case, the naive beamformer would have equal performance to the conventional beamformer. It would have all described advantages without listed disadvantages.

How can we estimate these differences? GNSS phase difference estimation is a well known problem. It is the base of GNSS attitude determination receivers. Several solutions of the problem are known.

In the study we used difference phase locking loops (DPLL) for this purpose [5]. DPLLs are not disturbed by a reference oscillator instability. As result, DPLLs may have very narrow noise bandwidth and, as a result, low noise errors (less than 1 degree) and good sensitivity (about 10 dBHz).

DPLLs process correlation sums for each antenna element. Each DPLL compares phases of the m -th and the first correlation sums by means phase difference discriminator:

$$u_{m1}(\tilde{\psi}_{m1}) = \cos(\tilde{\psi}_{m1}) [I_m Q_1 - Q_m I_1] - \sin(\tilde{\psi}_{m1}) [Q_m Q_1 + I_m I_1] \quad (2)$$

The discriminators are used in the 3rd order locking loops:

$$\hat{\mathbf{x}}_k = \tilde{\mathbf{x}}_k + \mathbf{K} \cdot u_{m1}(\tilde{\psi}_{m1}) \quad (3)$$

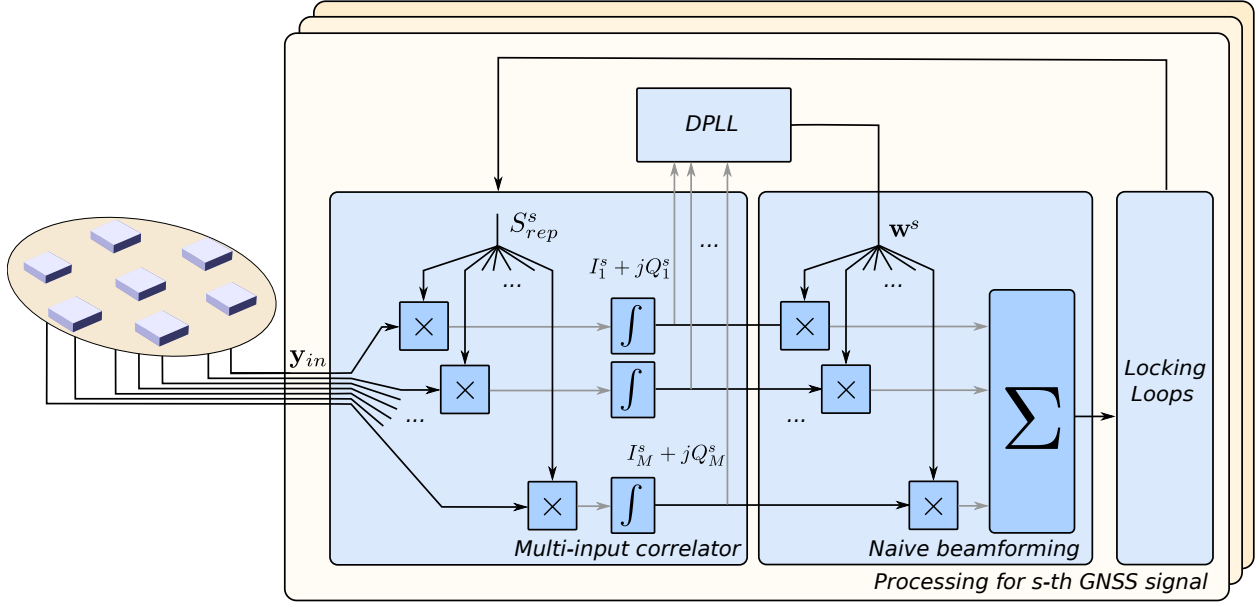

Figure 3: Naive beamforming technique: estimate phase differences and add signals together in-phase

where \mathbf{x}_k is the state vector for the k -th step

$$\mathbf{x} = |\psi_{m1} \quad \omega_\psi \quad \nu_\psi|^\top \quad (4)$$

and $\hat{\mathbf{x}}_k$ is the estimated one, $\tilde{\mathbf{x}}_k$ is the extrapolated vector:

$$\tilde{\mathbf{x}}_k = \mathbf{F}\hat{\mathbf{x}}_{k-1} \quad (5)$$

matrix \mathbf{F} defines state evaluation:

$$\mathbf{F} = \begin{bmatrix} 1 & T & 0 \\ 0 & 1 & T \\ 0 & 0 & 1 \end{bmatrix} \quad (6)$$

parameter T is the filter step interval, vector K is the filter coefficients. It defines the locking loop noise bandwidth.

The naive beamforming weights are obtained from the DPLLs state vectors as:

$$\mathbf{w}^\top = |e^{-j\psi_{M1}} \quad e^{-j\psi_{(M-1)1}} \quad \dots \quad 1| \quad (7)$$

and should be applied to (1).

The correlator performs linear transformation. Consequently, weighted accumulation can be moved to the output of the block. The resulting naive beamformer scheme is presented in Fig. 3.

It has several advantages in comparison with the conventional scheme (see Fig. 1).

The antenna-correlator interface is simplified. It contains the antenna element signals instead of dozens of focused signals. As result, the correlator has several inputs and is more complex. It is a disadvantage of the proposed approach.

The naive scheme needn't any additional information as the antenna system attitude and the calibration coefficients. Moreover, the attitude and the coefficients can be estimated during the naive scheme operation like GNSS attitude determination receivers do. Then, the receiver can be switched to the conventional weights computation. It is a software option, and it doesn't require any hardware modernization.

3. EXPERIMENTAL RESULTS

Experimental studies were conducted to prove the naive beamforming approach efficiency. Our experimental setup is based on a seven-element L1-band convex antenna array (see Fig. 4, [6], [7]).

The antenna contains the patch elements and low noise amplifiers. The amplifier's outputs are connected with a multi-input linear frontend by means of 20-meters coaxial cables (see Fig. 5).



Figure 4: Seven-element L1-band convex antenna based on a university building roof



Figure 5: The GNSS receiver mockup

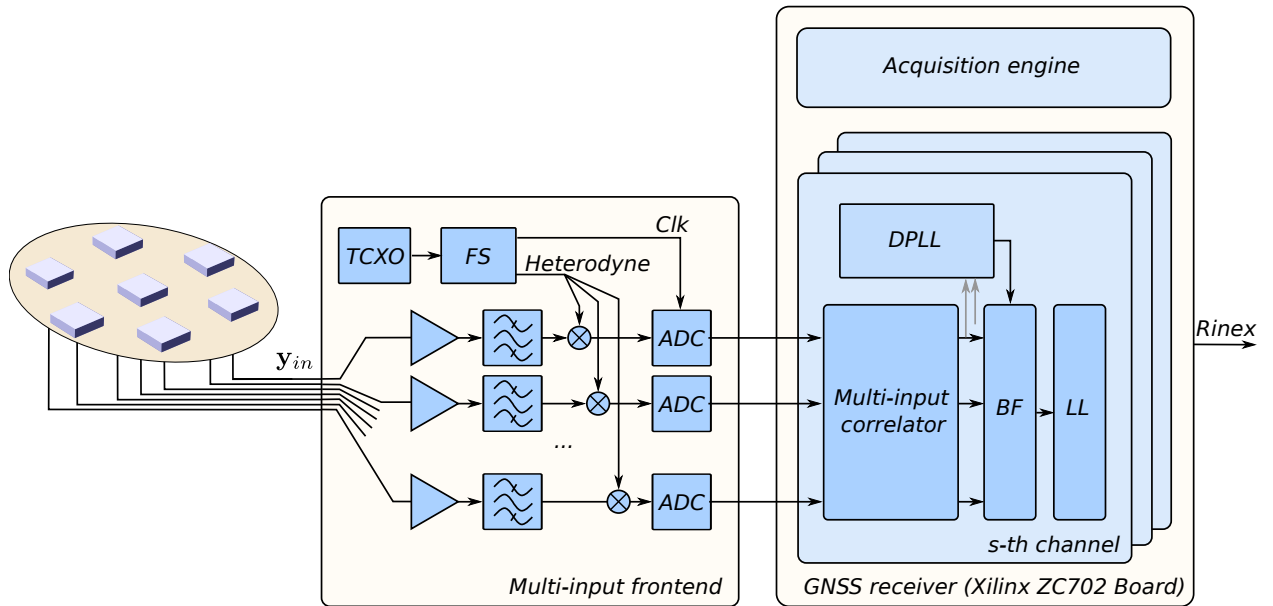

Figure 6: The experimental setup scheme

The frontend has the heterodyne architecture (see Fig. 6). It amplifies, filters the signals and performs analog-to-digital conversions.

The digital signals are processed by our custom FPGA-based GNSS receiver (CoreZh project). We used a Xilinx Zynq ZC702 board for this purpose.

The receiver contains an acquisition engine, several multi-input correlator channels, locking loops, interfaces and so on. The implementation of the multi-input correlator shows about 50% gain of ASIC/FPGA area consumption in comparison with the usual single-input correlator.

The proposed naive beamformer algorithm was implemented in the receiver firmware. We compared receiver performance with and without beamforming. In the second case, only one (the central) antenna element was used.

The naive beamforming switching “on” allows to increase SNR about 7-8 dB (see Fig. 7).

As result of the SNR gain, root-mean-square pseudorange errors decrease by 2-2.5 times as it shown on the Fig. 8.

4. CONCLUSION

The naive beamforming approach is presented. It is proposed to use estimated signal phase differences to combine the signals together in-phase, and, as a result, to form virtual radiation pattern focusing on a certain navigation satellite. The approach doesn't require knowing the antenna attitude and calibrating antenna elements and frontends. Moreover, it allows estimating the attitude

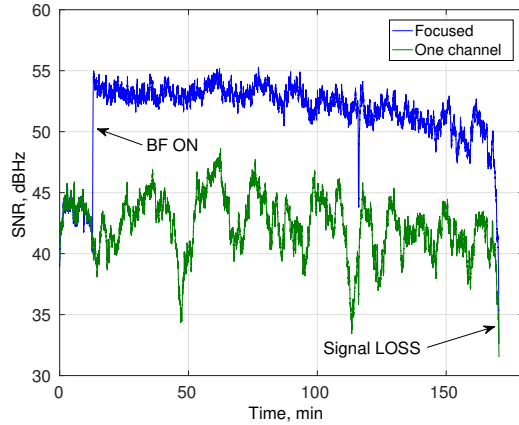

Figure 7: Signal-to-noise gain by the naive beamforming

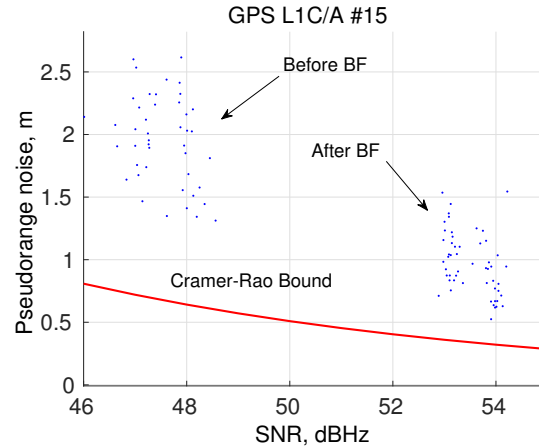

Figure 8: Root-mean-square error of pseudoranges before and after the naive beamforming

and the calibration coefficients during its operation. The naive beamforming is performed after the correlation stage, so it allows simplifying the correlator interface.

As a disadvantage, the approach requires changing the correlator structure to a multi-input configuration. As a result, the correlator consumes more ASIC/FPGA area (about 50% consumption gain).

The naive beamforming was realized in an FPGA-based GNSS receiver. The experiments with 7-element convex antenna array showed 7-8 dB SNR gain. Root-mean-square pseudorange errors decrease by 2-2.5 times.

ACKNOWLEDGMENT

This work was supported by the Ministry of Education and Science of the Russian Federation (project no. 8.9615.2017/BCh)

REFERENCES

1. Gunawardena, Sanjeev, Raquet, John, Carroll, Mark, "Correlator Beamforming for Multipath Mitigation at Relatively Low Cost: Initial Performance Results," Proceedings of the 29th International Technical Meeting of The Satellite Division of the Institute of Navigation (ION GNSS+ 2016), Portland, Oregon, September 2016, pp. 353-363.
2. G. Seco, J. A. Fernandez-Rubio, and C. Fernandez-Prades, ML estimator and Hybrid Beamformer for multipath and interference mitigation in GNSS receivers, *IEEE Trans. Signal Processing*, vol. 53, no. 3, pp. 1194-1208, March 2005.
3. R. A. Monzingo and T. W. Miller, *Introduction to Adaptive Arrays*. John Wiley & Sons, 1980.
4. B. D. V. Veen and K. M. Buckley, Beamforming: A versatile approach to spatial filtering, *IEEE Signal Processing Mag.*, vol. 5, no. 2, pp. 4-24, April 1988.
5. A. I. Perov, I. V. Korogodin, and O. E. Lopatko, Combined coherent-noncoherent system for orientation angels estimation using signals of space navigation systems, *Radiotekhnika*, vol. 7, pp. 88-98, 2009.
6. I. V. Korogodin, E. N. Boldenkov et al., The results of developnig a gnss-range seven-element convex antenna array, *Internavigaciya*, vol. 9, pp. 121-127, 2016.
7. I. V. Korogodin, A. I. Perov, V. V. Dneprov, and S. A. Savelyev, Experimental study of the characteristics of the navigation receiver with antenna array and focusing on navigation satellites, *Radionavigation technology*, pp. 100-105, 2016.